



2014 SCORPION UK NATIONAL CHAMPIONSHIPS

9th – 15th August 2014

TEIGN CORINTHIAN YACHT CLUB

Race Officer: Don Harrison
Results: Scorpion Association
Event Judge: Bill Handley
Beachmaster: Ray Potter

Organising Authority: Teign Corinthian Yacht Club in conjunction with the National Scorpion Class Association

SAILING INSTRUCTIONS

1 RULES

The Regatta will be governed by the Racing Rules of Sailing (RRS).

2 NOTICES TO COMPETITORS

Notices to competitors will be posted on the official notice board near the entrance to the TCYC Eastcliff clubhouse.

3 CHANGES TO SAILING INSTRUCTIONS

Any change to the sailing instructions will be posted at least 60 minutes before flag D is displayed (SI 4.2.1) on the day it will take effect, except that any change to the schedule of races will be posted by 19:00 hours on the day before it will take effect.

4 SIGNALS MADE ASHORE

4.1 Signals made ashore will be displayed from the flag mast near to the race administration point in the dinghy park.

4.2.1 Boats shall remain ashore until flag D is flown from the flag mast

4.2.2 If the warning signal for the first scheduled race of any day has to be postponed, flag AP will be flown ashore, with a numeral flag flown below it, to indicate the length of the postponement in hours.

5 SCHEDULE OF RACES

5.1

Date	Event / activity	Time
------	------------------	------

Saturday 9 th August	Registration	11:00h – 18:00h
	Measurement	11:00h – 17:00h
	Competitors' Briefing	18:30h
	Practice Race warning signal	14.55h
Sunday 10 th August	Registration	09:00h – 10:00h
	1st warning signal – 2 races scheduled	10:55h
Monday 11 th August	1st warning signal – 1 races scheduled	10:55h
	Crews race	Back to back
Tuesday 12 th August	1st warning signal - 2 races scheduled	10:55h
Wednesday 13 th August	1st warning signal – 1 race scheduled	10:55h
Thursday 14 th August	1st warning signal - 2 races scheduled	10:55h
Friday 15 th August	1st warning signal - 1 race scheduled	10:55h
	Prize giving	TBA

5.2 If the practice race has not started by 1600h, it may be abandoned and the first race sailed will be Race 1.

5.3 On the last day of the Regatta no warning signal will be made after 1355 unless fewer than four races have been completed, in which case no warning signal will be made after 1555.

6 CLASS FLAGS

The class warning signal will be yellow flag with a red horizontal band, naval numeral 2.

7 RACING AREAS

Racing will take place offshore Teignmouth with the start line within an area of up to 2 miles from the mouth of the river. A chart of this area will be displayed in the Club house.

8 THE COURSES

8.1 The diagrams in Annex A show the courses, the order in which marks are to be passed, and the side on which each mark is to be left.

8.2 No later than the warning signal, the Committee boat will display the approximate compass bearing of the first leg.

9 MARKS

9.1 Course marks will be 5ft cylindrical orange buoys.

9.2 The starboard end starting mark will be the Committee boat displaying an orange flag. The port end will be a 6ft danbuoy with an orange flag.

9.3 Finishing marks will be a boat displaying a blue flag and a 6ft danbuoy with a blue flag.

9.4 A race committee boat, signalling a change of a leg of the course is a mark as provided in SI 11.1

9.5 The substitute mark will be a red spherical buoy

10 THE START

- 10.1 For line starts, the starting line will be between the main mast of the committee boat displaying an orange flag at the starboard end of the start line and a 6 ft dan buoy with an orange flag at the port end.
- 10.2 Flag G displayed from the Committee boat indicates a Gate Start (see Annex C).
- 10.3 A boat starting later than 5 minutes after her starting signal will be scored *did not start*, this changes Rule A4.2 and A5
- 10.4 The committee boat at the starting line may hold station using engines.

11 CHANGE OF THE NEXT LEG OF THE COURSE

- 11.1 To change the next leg of a course, the race committee will move the original mark, or the finishing line, to a new position. If the mark/finishing line is moved less than 200 metres from its original position, the change will not be signalled. If the mark/finishing position is moved more than 200 metres from its original position, the change will be signalled before the leading boat begins that leg. This changes RRS rule 33.

12 SHORTENING COURSE

- 12.1 Changing (shortening) course to the finish. If a patrol boat displaying Flag F, and making repetitive sound signals is on station in the vicinity of Mark 3 (leeward mark), boats shall round Mark 3 and proceed directly to the finish, the Committee boat on station at the finish will display Flag S with 2 (two) sound signals. This is in addition to Race Signal S and changes Rule 33.

13 THE FINISH

- 13.1 The finish line will be between the mast of the finish boat flying a blue flag and 6ft dan buoy with a blue flag.
- 13.2 The boat at the finish line may hold station using engines.
- 13.3 At the discretion of the Race Officer, a tail-ender who has lost contact with the body of the fleet may be told on the water, towards the end of the race, that they need not complete that lap. An appropriate position will be recorded. Failure to take advantage of this provision when races are held back-to-back, may result in the next race being started before that competitor has returned to the starting area. This shall not be grounds for redress. This alters Rule 35 and A4.

14 PENALTY SYSTEM

- 14.1 RRS, Appendix P will apply
- 14.2 Penalties for breaches of class rules shall be at the discretion of the protest committee and will range from no penalty to disqualification. This changes rule 64.1.

15 TIME LIMIT

- 15.1 The time limit for course 'L' will be 2 hours 30mins from the starting signal. The time limit for course 'W' will be 3 hours from the starting signal.
- 15.2 When the first boat finishes within the last hour of the time limit then the time limit shall be extended to one hour after the finishing time of the first boat. Boats failing to finish within the time limit or its extension may be scored Did Not Finish without a hearing. This changes rules 35, A4 and A5.

16 PROTESTS AND REQUESTS FOR REDRESS

- 16.1 The Advisory Hearing and RYA Arbitration procedures of the RYA Rules Disputes Process will be available. For these purposes an Exoneration Penalty of 20% will apply, although the final position of a penalised boat will be no worse than if she had retired.
- 16.2 Protest forms will be available at the race administration point.
- 16.3 The protest time limit is 45 minutes after the last boat has finished the last race of the day. Protest time may be extended at the discretion of the event judge.
- 16.4 Notices will be posted within 30 minutes of the protest time limit to inform competitors of hearings in which they are parties or named as witnesses.
- 16.5 Notices of protests by the race committee or protest committee will be posted to inform boats under rule 61.1(b).
- 16.6 On the last scheduled day of racing a request for reopening a hearing shall be delivered:
- a. Within the protest time limit if the requesting party was informed of the decision on the previous day
 - b. No later than 30 minutes after the requesting party was informed of the decision on that day. This changes rule 66.
- 16.7 On the last scheduled day of racing, a request for redress from a protest committee decision shall be delivered no later than 30 minutes after the decision was posted. This changes Rule 62.2.
- 16.8 A whistle blown by a member of the protest committee during a race means a member of the protest committee believes a boat has broken a rule.

17 SCORING

Nine races scheduled, of which three shall be completed to constitute a championship. There will be one discard if four to eight races are completed and two discards if nine races are sailed.

18 SAFETY REGULATIONS

- 18.1 Competitors shall wear adequate personal flotation devices at all times whilst afloat, except briefly while changing or adjusting clothing or equipment. This changes the preamble to Part 4 and Rule 40.
- 18.2 The tally board will be situated in or near the beachmasters' office. The release of dinghies from the beach will be under the control of the Beachmaster. On leaving the boat park to race the helm and crew of each boat will collect a wrist band which bears the competitor's tally number issued at registration. The band will be worn on the wrist at all times when afloat and returned to the beachmaster within 15 minutes of coming ashore. In addition, every boat shall have its own launching trolley to which shall be attached on its handle a tag or ribbon bearing the competitor's tally number. All competitors shall return to shore without unnecessary delay when they have finished racing for the day.
- 18.3 Boats whose crew fails to comply with SI 18.2 may accept an alternative penalty for a first infringement by making a donation of £10 to the local RNLI, otherwise the penalty will be a score of DSQ. A list of boats that have infringed will be posted on the official notice board as soon as possible after the end of protest time and within 30 minutes of that time. This changes rule 63.1.
- 18.4 Boats not participating in any of the day's racing shall inform the Beachmaster.
- 18.5 A boat that retires from a race shall notify the Committee boat or a race patrol boat, as soon as possible.

19 REPLACEMENT OF CREW OR EQUIPMENT

Substitution of competitors will not be allowed without prior written approval of the race committee.

20 EQUIPMENT AND MEASUREMENT CHECKS

A boat or equipment may be inspected at any time for compliance with the class rules and sailing instructions. On the water, a boat can be instructed by a race committee measurer to proceed immediately to a designated area for inspection.

21 SUPPORT BOATS

Team leaders, coaches and other support personnel shall stay more than 100 metres outside areas where boats are racing from the time of the first preparatory signal until all boats have finished or the race committee signals a postponement or abandonment, unless attending a boat in distress requiring assistance, or as directed by the race committee. NOTE – This SI does not permit such boats to enter the area during a general recall.

23 PRIZES

Individual Race Prizes will be awarded as follows:

Practice Race	Sidmouth Trophy
Race 1 sponsored by	Marlow Ropes Trophy
Race 2 sponsored by	Dunhill Trophy
Race 3 sponsored by	City of Plymouth Cup
Race 4 sponsored by	Gosling Dinghy Craft
Race 5 sponsored by	Designer's Cup
Race 6 sponsored by	Trevor Stuart Cup
Race 7 sponsored by	President's Pot
Race 8 sponsored by R	Chapman Quart
Race 9 sponsored by	Kensitas Trophy

The overall prize for the series will be the Scorpion National Class Association Owner's Trophy

25 DISCLAIMER OF LIABILITY

Competitors participate in the regatta entirely at their own risk. See RRS4, Decision to Race. The organising authority will not accept any liability for material damage or personal injury or death sustained in conjunction with, or prior to, during, or after the regatta.

26 INSURANCE

Each participating boat shall be insured with valid third-party liability insurance with a minimum cover of £2 million (two million pounds) per event or the equivalent.

27 NAVIGATIONAL WARNING

Teignmouth is a working port and commercial shipping and fishing boats may enter or leave the port at or around High Water. Such shipping is constrained by its draught and shall be given proper clearance by competing boats.

The event has been sponsored by:



Annex A - Courses

Course 'L'

Order of rounding:

Start - 1 - 2 - 3 - 1 - 3 - 1 - 2 - 3 - 1 - 3 - Leeward finish

All marks left to port.

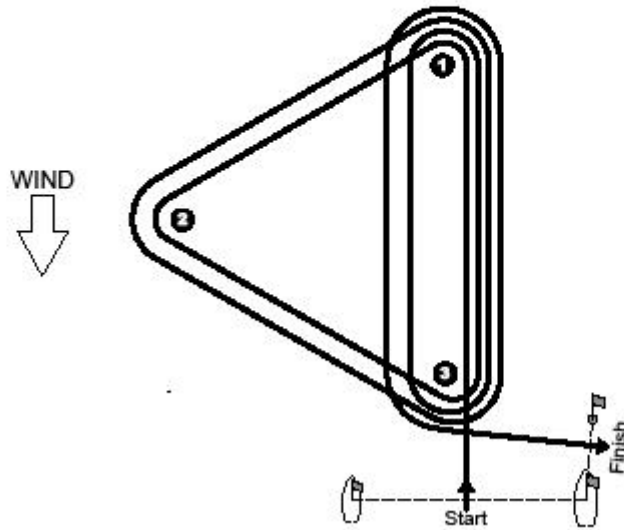

Course 'W'

Order of rounding:

Start - 1 - 2 - 3 - 1 - 3 - 1 - 2 - 3 - 1 - 3 - Windward finish

All marks left to port.

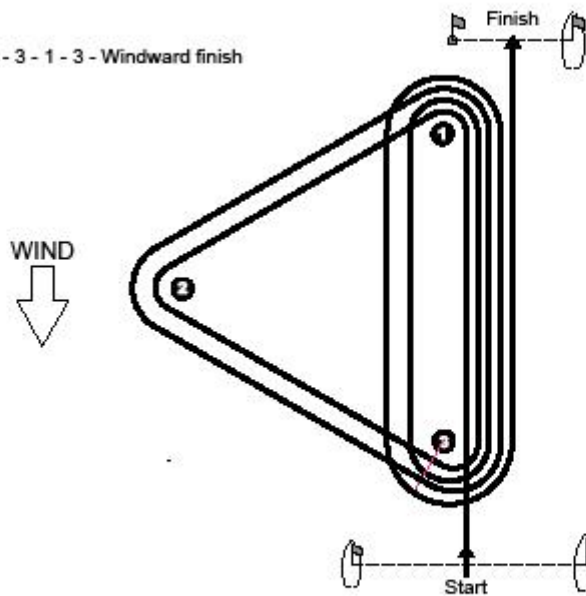

The full course will comprise 4 (four) rounds plus a finishing leg. Mark 1 is the intended windward mark, Mark 2 and Mark 3 may not be laid until after the start. If laid, Mark 3, intended leeward Mark, will not rank as a mark of the course on the first leg. The diagrams indicate the number of legs required to complete particular rounds. Mark 1 may be ignored on the finishing leg if the full course is sailed. The port end of the start line will be a 6ft danbuoy with an orange flag and not a committee boat as shown on the diagram

Annex B: Tide Times

Times of High and Low Water are shown below. All times are BST.

	Time	Height (mtrs)	HW/LW
Sat 9 Aug:	06.03	4.04	HW
	11.52	1.26	LW
	18.28	4.43	HW
Sun 10 Aug	00.24	0.99	LW
	06.57	4.36	HW
	12.44	0.89	LW
Mon 11 Aug	19.19	4.78	HW
	01.12	0.62	LW
	07.44	4.66	HW
Tues 12 Aug	13.31	0.57	LW
	20.05	5.05	HW
	01.57	0.34	LW
Wed 13 Aug	08.29	4.87	HW
	14.16	0.36	LW
	20.49	5.19	HW
Thurs 14 Aug	02.40	0.22	LW
	09.32	4.94	HW
	14.59	0.32	LW
Fri 15 Aug	21.32	5.17	HW
	03.23	0.28	LW
	09.54	4.87	HW
	15.41	0.45	LW
	22.14	5.00	HW
	04.50	0.50	LW
	10.37	4.68	HW
	16.24	0.73	LW

ANNEX C – GATE STARTS**THE START (GATE START)**

- 10.3.1 Flag G displayed from the Committee boat indicates a Gate Start
- Races will be started in accordance with Rule 26, with the warning signal given 5 minutes before the starting signal
- 10.3.2 Starting marks for a gate start will be the port limit mark (which will be a dan buoy with a red flag), the gate launch displaying flag G, the guard launch displaying flag U, and the pathfinder (until released).
- 10.3.3 Starting Area: The Committee boat will be in the starting area, which will be to leeward of the course. The port limit mark will be laid at the leeward end of the gate.
- 10.3.4 Distinguishing Flags & Signals: The Committee boat and gate launch will display flag G. When used, the guard launch will display flag U. The starting signals will be made from the Committee boat.
- 10.3.5 Direction of Pathfinder: The race committee will nominate the pathfinder and a reserve pathfinder for the first race. Subsequently, the pathfinder will be the tenth boat in the preceding race. When she is unable to race, or has been the pathfinder previously in the event, the pathfinder will be the eleventh boat in the preceding race and so on. The reserve pathfinder will be the next boat in the previous race. The sail numbers of pathfinder and reserve for the first race of each day will be posted on the official notice board, and will be displayed on the side of the Committee boat at least 10 minutes before the warning signal for the first race. If more than one race is sailed on the same day, the numbers will be displayed on the side of the Committee boat at least 10 minutes before the warning signal for each successive race. The pathfinder and reserve shall report to the Committee boat as soon as possible after her number is displayed and before the warning signal. A pathfinder or reserve that fails to report will be scored Did Not Start. This changes rules A4 and A5.
- 10.3.6 Positioning of Pathfinder, Gate Launch and Guard Launch: At or up to 15 seconds before the starting signal the pathfinder shall commence her close-hauled port tack from within one boat length of the port limit mark, leaving the mark to port, followed by the gate launch which will keep close astern of her. If the pathfinder is unable to do this, the race committee will signal a general recall. When used, the guard launch will protect the pathfinder and will keep station off her starboard bow. There will be no penalty if the pathfinder touches the port limit mark. This changes rule 31 for the pathfinder.
- 10.3.7 Starting Line: The starting line for all boats except the Pathfinder shall be between the port limit mark and the centre of the stern of the Gate Launch. The Gate Launch, Guard Launch and Pathfinder until released, all rank as starting marks. Any boat, which crosses a line between the port limit mark and the centre of the stern of the Gate Launch after the one-minute signal and before the starting signal, shall be disqualified without hearing. This changes RRS 63.1. If the race is restarted, re-sailed, or rescheduled, she is not entitled to compete. This changes RRS 36.
- 10.3.8 Pathfinder Course: The approximate time that the gate launch will be in motion along the port tack course after the starting signal will be displayed on the starboard side of the Committee boat before the warning signal. The pathfinder shall maintain her close-hauled course for a minimum of 2 minutes or longer at the discretion of the race officer, then will be released by a hail from the gate launch, and may tack onto starboard. After releasing the pathfinder, the gate launch and guard launch will maintain their course and speed. At the end of the period of time displayed on the Committee boat (which may be extended at the discretion of the race officer) the gate launch will stop, lower flag G half way with a sound, and drift for at least one minute. Flag G will then be fully lowered with a sound to indicate the closing of the gate.
- 10.3.9 Starting: Boats other than the Pathfinder shall start by crossing the starting line on starboard tack after the starting signal and before the Gate closes. A boat which has not already started correctly, and which is on the course side of the starting line while the gate is open, or which crosses the starting line from the course side, shall be disqualified without a hearing. This changes RRS63.1. If the race is restarted, re-sailed, or rescheduled, she is not entitled to compete. This changes RRS 36. No boat shall be permitted to start after the gate start line is closed

- 10.3.10 Interference with Pathfinder, Gate Launch and Guard Launch: After the preparatory signal, a boat shall not threaten the unobstructed sailing, or in any other way impede the sailing performance of the Pathfinder until she is released. A boat which interferes with or tries to pass between the Pathfinder and the Gate Launch or Guard Launch, or that causes another boat to interfere in these ways, will be disqualified without a hearing. This changes RRS63.1. If the race is restarted, re-sailed or rescheduled she is not entitled to compete. This changes RRS 36.
- 10.3.11 Hailing for room on a starting Mark: A boat that cannot avoid touching a starting mark may hail a right-of-way boat for room and the right of way boat shall give her room. The hailing boat shall then immediately retire from the race. If the race is restarted, re-sailed or rescheduled she is not entitled to compete. This changes RRS 36. If a boat that cannot avoid touching a starting mark does not hail for room but takes room to which she is not entitled and thereby infringes a right of way boat the same penalty will apply.
- 10.3.12 The guard launch, pathfinder and gate launch all rank as start line marks. Any boat touching a starting line mark will be disqualified without a hearing. This alters RRS 44.2 and 63.1.